

SONY



Compact handy camcorder delivers broadcast quality 4K and Full-HD

Ready for any shooting scenario, Sony's PXW-Z150 handy professional camcorder delivers stunning 4K image quality, 120fps HFR Full-HD slow-motion and built-in advanced networking for live streaming and wireless workflow.

PXW-Z150

Solid-State Memory Camcorder

XDCAM

4K

Exmor RS
CMOS Sensor

XAVC

MPEG HD422

WiFi
CERTIFIED





Breakthrough 4K imaging performance

Stunning imagery with world's first 1.0 type stacked CMOS sensor*

*for professional camcorder

1.0 type 120 fps HFR Revolutionary imaging performance with Exmor RS™

To deliver imaging performance previously impossible for a compact camcorder, Sony has developed the world's first 1.0 type stacked CMOS image sensor for professional video applications. A 2x increase in read-out speed, compared to a conventional 1.0 type sensor, enables beautiful 5x slow motion image capture up to 120fps in Full HD and high resolution 4K recording with full pixel readout without binning.

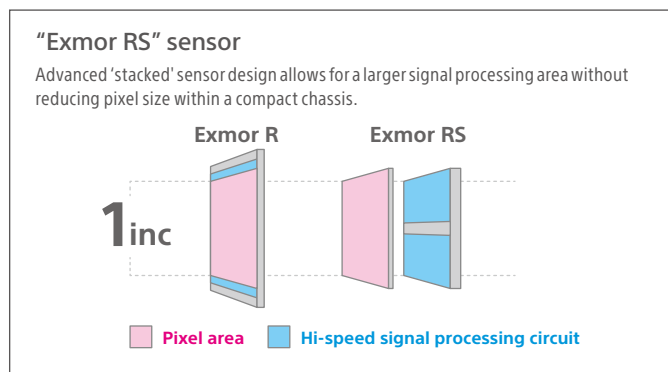

Max. 24x zoom

Sony "G" lens with maximum 24x zoom

To maximise the quality of your images, the Z150 has a stunning optical 12x zoom lens that offers high resolution and contrast across the entirety of the image. Sony's advanced Clear Image Zoom feature doubles magnification to 18x when shooting in 4K QFHD and 24x in HD, to fully exploit the imaging capabilities of the Z150's large 1.0 type stacked sensor.

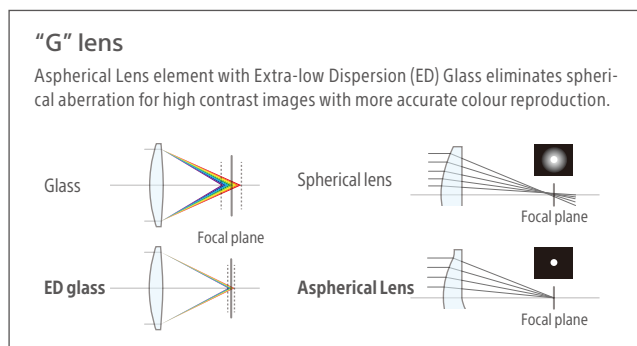

XAVC

4K QFHD Long GOP 4:2:0 8bit 100Mbps
Full HD Long GOP 4:2:2 10bit 50Mbps

MPEG2 HD

AVCHD

Flexible 4K and Full HD recordings

Stunning 4K picture performance is supported with 4K QFHD (3840x2160) XAVC Long GOP at 100Mbps, while integration with established broadcast workflows is simplified with Full HD recording in XAVC Long GOP(4:2:2/10bit 50Mbps) and MPEG-2 HD (50Mbps/35Mbps). You can even use AVCHD to further expand workflow flexibility. However you want to shoot, the Z150 delivers.

The perfect handy camcorder

Lightweight and easy to use with integrated Wi-Fi

1.9 kg camerabody

3 Independent lens rings

Compact and lightweight body

The Z150 is ergonomically designed to provide a lightweight and easy-to-use shooting experience. Three manual, independent lens rings enable smooth, natural adjustment of focusing, zooming and iris control. The camcorder can also be used in full-auto mode or completely manual for maximum creative control. Exceptional 6.3W power efficiency offers high performance within a compact handycam body without compromising battery life. Up to 400 minutes with optional NP-F970.*

* While recording XAVC 1080/50i or 60i, 50Mbps with LCD on.



High resolution monitoring

The Z150 gives you precise monitoring and low latency, however you choose to shoot, with its advanced, wide viewing-angle and high contrast 0.39 type 1440K dots OLED electronic viewfinder (EVF) with large eye-cap, and an easily adjustable, flip-out 3.5 type 1550K dots LCD panel.



Multi-Interface (MI) Shoe

The Z150 takes advantage of Sony's flexible Multi-Interface (MI) Shoe, which provides power, signal connections and coordinated on/off switching to compatible Sony accessories. For example, you can connect and control Sony wireless microphone systems such as the UWP-D11 or UWP-D12 or attach the HVL-LBPC light*.

* All sold separately. HVL-LBPC is controlled but not powered by Z150.

Wireless

Networked for high mobility

The Z150 has advanced networking capabilities that give you more mobility in your work - FTP files directly from the camcorder or live stream from any event using built-in Wi-Fi features with no accessories required. Sony's unique QoS technology* dramatically improves the clarity that's possible on a wireless connection, giving you better pictures even with the limitations of today's real-world networks.

You can also remotely control the PXW-Z150 with a smartphone or tablet, including the ability to adjust settings such as focus, zoom, iris, white balance, REC START/STOP and more using Sony's Content Browser Mobile** software.

* QoS will initially require a firmware update and PWS-100RX1 receiver.

** The Content Browser Mobile application can be downloaded from the Google Play Store or App Store.



Wide choice of connections including 3G-SDI

There's no need to worry about adapters as the Z150 provides a wide variety of built-in connectivity options including 3G-SDI, HDMI, Multi/Micro USB, professional audio XLR terminals, REMOTE and Composite (RCA). A supplied Sony cold shoe adaptor kit provides you with more flexibility for mounting accessories.



Dual media slots for recording flexibility

To extend recording times and workflow flexibility, the Z150 is equipped with two memory card slots and is compatible with SDXC and SDHC cards.

"RELAY" mode automatically switches recording from the first to the second memory card when the first is full, while "SIMUL" mode permits simultaneous recording to two memory cards (for example to create an immediate back-up version).

Specifications

| PXW-Z150 | |
|------------------------------|--|
| General | |
| Mass | Approx. 1895g (Body only) Approx. 2270 g (with lens hood, eyecup, NP-F770 battery) |
| Dimensions (W x H x D)* | 171.3 × 187.8 × 371.3 mm (With the accessories (lens hood, large eyecup), excluding the grip belt and including the projecting parts) |
| Power Requirements | DC In: 8.4V, Battery: 7.2 V |
| Power Consumption | Approx. 6.3 W (while recording with viewfinder and XAVC HD 1080/60i 50 Mbps) Approx. 6.6 W (while recording with LCD and XAVC HD 1080/60i 50 Mbps) |
| Operating Temperature | 0°C to 40°C (32°F to 104°F) |
| Storage Temperature | -20°C to +60°C (-4°F to +140°F) |
| Battery Operating Time | Approx. 260 min. with NP-F770 battery (while recording with LCD, XAVC 1080/60i, 50 Mbps) Approx. 400 min. with NP-F970 battery (while recording with LCD, XAVC 1080/60i, 50 Mbps) |
| Lens | |
| Lens Mount | Fixed |
| Zoom Ratio | 12x (optical), servo |
| Focal Length | f = 9.3 - 111.6 mm, equivalent to f = 29.0 - 348.0 mm on 35 mm lens (16:9) |
| Iris | F2.8 - F4.5 auto/manual selectable |
| Focus | AF/MF selectable, 10 mm to ∞ (Wide), 1000 mm to ∞ (Tele) |
| Image Stabilizer | On/Off selectable, shift lens |
| Filter Diameter | M62 mm |
| Camera Section | |
| Imaging Device (Type) | 1.0-type (13.2 mm x 8.8 mm) back-illuminated Exmor RS CMOS sensor |
| Effective Picture Elements | 3840 (H) x 2160 (V) |
| Built-in Optical Filters | ND filters OFF: CLEAR 1: 1/4ND 2: 1/16ND 3: 1/64ND |
| Minimum Illumination | 1.7 lux (Low Lux) |
| Shutter Speed | [60i]: 1/8 - 1/10,000 (1/6 - 1/10,000 when shooting with 24p) [50i]: 1/6 - 1/10,000 |
| Slow & Quick Motion Function | [60i]: XAVC HD: Frame rate selectable 1.2, 4.8, 15, 30, 60 fps [50i]: XAVC HD: Frame rate selectable 1.2, 3.6, 12, 25, 50 fps [60i]: MPEG HD: Frame rate selectable 1.2, 4.8, 15, 30 fps [50i]: MPEG HD: Frame rate selectable 1.2, 3.6, 12, 25 fps [60i]: AVCHD: Frame rate selectable 1.2, 4.8, 15, 30, 60 fps [50i]: AVCHD: Frame rate selectable 1.2, 3.6, 12, 25, 50 fps |
| Super Slow Motion Function | [60i]: XAVC HD: Frame rate selectable 120 fps [50i]: XAVC HD: Frame rate selectable 100 fps |
| White Balance | Preset (Indoor: 3200K, Outdoor: 5600K) 7 steps, Color temperature set range: 2300-15000K), Onepush A, B, Auto selectable |
| Gain | -3, 0, 3, 6, 9, 12, 15, 18, 21, 24, 27, 30, 33 dB, AGC |
| Gamma Curve | Selectable |

| PXW-Z150 | |
|-----------------------------|--|
| Input/Output | |
| Audio Input | XLR-type 3-pin (female) (x2), line/mic/mic +48 V selectable |
| Video Output | Integrated into Multi/Micro USB jack (x1), RCA pin(x1), Composite 1.0Vp-p, 75 Ω |
| Audio Output | Integrated into Multi/Micro USB jack(x1), RCA pin(Monaural)(x1) |
| SDI Output | BNC (x1), 3G/HD/SD SMPTE ST 424/ST 292-1/ST 259 standards |
| HDMI Output | HDMI connector (Type A) |
| USB | Multi/Micro USB jack (x1) |
| Headphone Output | Stereo mini jack (x1) |
| Speaker Output | Monaural |
| DC Input | DC jack |
| Remote | Stereo mini-minijack (ø2.5 mm) |
| Monitoring | |
| LCD Monitor | 8.8 cm (3.5 type), Approx. 1.56M dots |
| Viewfinder | 1.0cm(0.39 type)OLED Approx. 1.44M dots |
| Built-in Microphone | |
| | Omni-directional stereo electret condenser microphone |
| Media | |
| Type | MS/SD(1),SD(1) |
| Wi-Fi/NFC | |
| Supported Format | IEEE 802.11 b/g/n |
| Frequency Band | 2.4 GHz bandwidth |
| Security | WEP/WPA-PSK/WPA2-PSK |
| NFC | NFC Forum Type 3 Tag compliant |
| Supplied Accessories | |
| | Lens hood (1) Large eyecup (1) Shoecap (1) Accessory shoe kit (accessory shoe (1), accessory shoe plate (1), screws (4)) USB cable (1) AC Adaptor (AC-L100 C) (1) Power cord (mains lead) (1) Rechargeable battery pack (NP-F770) (1) Charger(BC-L1) (1) Wireless Remote Commander (RMT-845) (1) Lithium battery (CR2025 for the Wireless Remote Commander) (1), Pre-installed to the Wireless Remote Commander Operating Guide (2) CD-ROM "Manuals for Solid-State Memory Camcorder" (1) Warranty (1) |

* The values for dimensions are approximate.

| | Format | Bitrate | Definition | Recording frame rate | Audio format | Recording time 64G SD card | | |
|--------|--|--------------|-------------------------------|--|---|------------------------------|------------------------------|-----------------|
| 4K | XAVC Long MPEG-4 AVC/H.264 | 100Mbps | 3840 x 2160 | 29.97p, 25p, 23.98p | Linear PCM 2ch, 24bit, 48kHz | Approx. 65 min | | |
| | | 60Mbps | | 29.97p, 25p, 23.98p | | Approx. 100 min | | |
| | XAVC Long MPEG-4 AVC/H.264 | 50Mbps | 1920×1080 | 59.94p, 50p, 59.94i, 50i, 29.97p, 25p, 23.98p, | | Linear PCM 2ch, 16bit, 48kHz | Approx. 120 min | |
| | | 35Mbps | 1920×1080 | 59.94p, 50p, 59.94i, 50i, 29.97p, 25p, 23.98p, | | | Approx. 170 min | |
| HD | MPEG HD 4:2:2 (MPEG-2 422P@HL) | 50Mbps | 1920×1080 | 59.94i, 50i, 29.97p, 25p, 23.98p | Linear PCM 2ch, 16bit, 48kHz Dolby Digital 2ch, 16bit, 48kHz | | Approx. 220 min | |
| | | | 1280×720 | 59.94p, 50p | | | Approx. 120 min | |
| | MPEG HD 4:2:0 (MPEG-2 MP@HL) | 35Mbps | 1920×1080 | 59.94i, 50i, 29.97p, 25p, 23.98p | | Linear PCM 2ch, 16bit, 48kHz | Approx. 170 min | |
| | | | 1280×720 | 59.94p, 50p | | | Approx. 290 min | |
| | AVCHD MPEG-4 AVC/H.264 AVCHD 2.0 format compatible | 28Mbps | 1920×1080 | 59.94i, 50i/29.97p/25p/23.98p, | | | Linear PCM 2ch, 16bit, 48kHz | Approx. 340 min |
| | | | 24Mbps | 1280×720 | | | | 59.94p, 50p, |
| 17Mbps | | 1920×1080 | 59.94i/50i/29.97p/25p/23.98p, | Approx. 750 min | | | | |
| | | 1280×720 | 59.94p, 50p, | | | | | |
| 9Mbps | 1280×720 | 59.94p, 50p, | | | | | | |

Accessories



Dimensions

Unit: mm (inches)

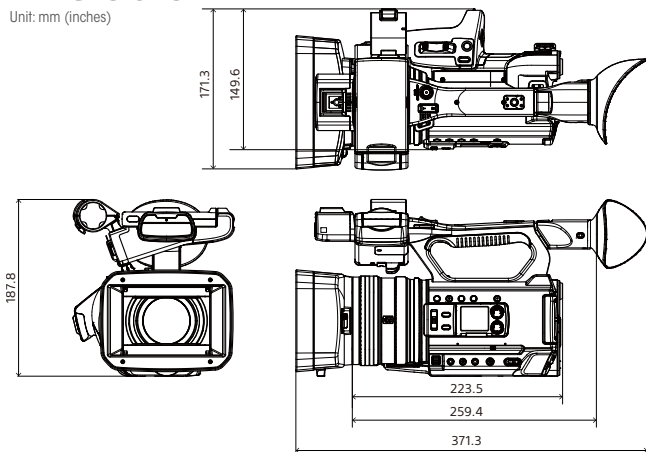

©2016 Sony Corporation. All rights reserved.

Reproduction in whole or in part without written permission is prohibited.

Features and specifications are subject to change without notice.

The values for mass and dimension are approximate.

Sony and Sony logo are trademarks of Sony Corporation.

AVCHD and AVCHD logo are trademarks of Panasonic Corporation and Sony Corporation.

XDCAM, XAVC, MPEG HD422 and their respective logos are trademarks of Sony Corporation.

All other trademarks are the property of their respective owners.

Distributed by