



## OUTLINE

*The Sony ECM-674 is an affordable shotgun-type electret condenser microphone, which delivers excellent sound performance in field and studio productions. Offering high-sensitivity, low-noise characteristics and flat-and-wide frequency response in a compact and lightweight design, the ECM-674 is well-suited for use with Sony camcorders such as the HDV™ Series, DVCAM™ Series, and XDCAM™ Series. In addition, its two-way powering feature allows for both microphone power operation and battery operation. With its high performance, affordable price, and great versatility, the ECM-674 microphone is an ideal choice for a range of sound-acquisition applications.*

## FEATURES

### Superb Sound Quality

The ECM-674 offers an excellent sensitivity of -36 dB (0 dB=1 V/Pa.) and low inherent-noise level of less than 19 dB SPL. This allows the microphone to be used for clear voice pick-up even in noisy environments.

### Flat-and-wide Frequency Response

The ECM-674 microphone has a flat-and-wide frequency response (60 Hz to 18 kHz) and provides sound reproduction that is extremely smooth and natural.

### Compact and Lightweight Design

The ECM-674 has been designed as a highly directional compact and lightweight shotgun microphone. It measures only 268 mm (10 5/8 inches) in length and weighs just 220 g (7 oz), maintaining good balance even when mounted on compact camcorders.

### Two-way Powering

A two-way powering capability allows the ECM-674 to be driven by microphone power or batteries, making it suitable for both camcorder mounting and many other sound-gathering applications.

- Internal AA-size battery operation
- External DC (40 to 52 V) operation

### Built-in Low Cut Filter

The built-in two-position (M, V) low-cut switch provides users with a simple method of reducing the effects of undesired ambient noise.

# SPECIFICATIONS

ECM-674	
Capsule type	Electret condenser
Directivity	Uni-directional (super-cardioid)
Frequency response	60 Hz to 18 kHz
Sensitivity (at 1 kHz)	-36 dB* <sup>1</sup> ±3 dB
Output impedance (at 1 kHz)	200 Ω ±20%
Dynamic range	90 dB or more
Signal-to-noise ratio	74 dB or more (IEC179 A-weighted, 1 kHz, 1Pa.)
Inherent noise	19 dB SPL* <sup>2</sup> or less
Wind noise	60 dB SPL* <sup>2</sup> or less
Induction noise from external magnetic field	0 dB SPL* <sup>2</sup> or less
Maximum input sound pressure level	109 dB SPL* <sup>2</sup>
Power requirements	External: DC 40 to 52 V, Battery: 1.5 V
Dimensions	ø20 x 268 mm (ø13 <sup>1</sup> / <sub>16</sub> x 10 <sup>5</sup> / <sub>8</sub> inches)
Mass	220 g (7 oz)

\*<sup>1</sup> 0 dB=1 V/Pa., at 1 kHz

\*<sup>2</sup> 0 dB=20µ Pa.

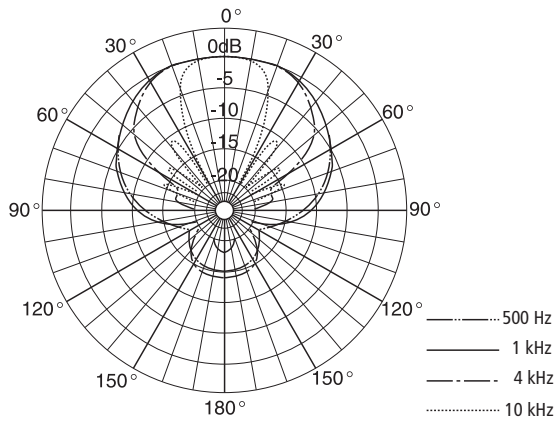

Directivity Characteristics

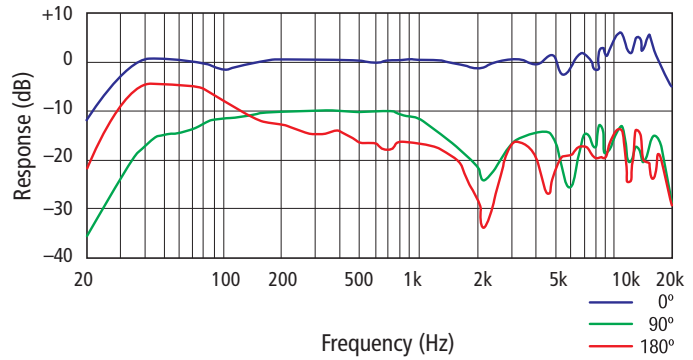

Frequency Response Characteristics

## SUPPLIED ACCESSORIES

- Windscreen (x1)
- Microphone spacer (x1)
- Operating instructions (x1)



### Distributed by

©2005 Sony Corporation. All rights reserved.  
 Reproduction in whole or in part without written permission is prohibited.  
 Features and specifications are subject to change without notice.  
 All non-metric weights and measurements are approximate.  
 Sony, DVCAM, and XDCAM are trademarks of Sony Corporation.  
 HDV and HDV logo are trademarks of Sony Corporation and Victor Company of Japan, Limited (JVC).